

Part A

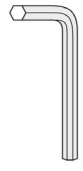

x 2

Part B



x 1

Part C

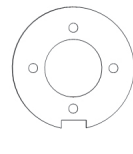

x 2

Part D



x 1 (98mm)

Part E



x 4

Part F



x 4

Part G



x 4

Part H



x 4

Step 1:

Insert the spindle (part D) through the existing hole in the door.

*if it is a new door fit in your new latch before drilling any holes.

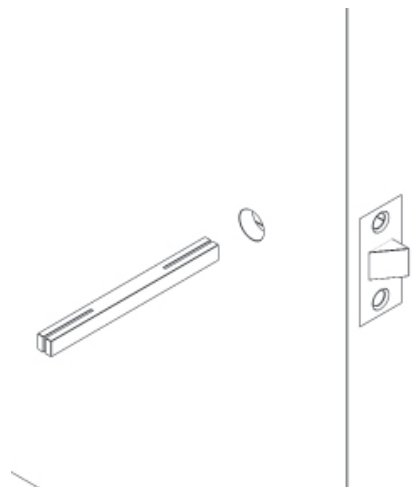

Step 2:

Line up the cylinder (part C) to the hole and mark the holes with a pencil.

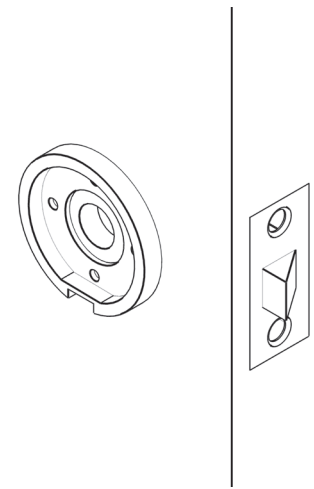

Step 3A:

Drill the marked holes.

NOTE:

Top and Bottom (1)
Pilot holes for wood screws.

*Do not drill all the way through, shallow drill to avoid wood splitting when fixing in wood screws.

Top and Bottom (1)

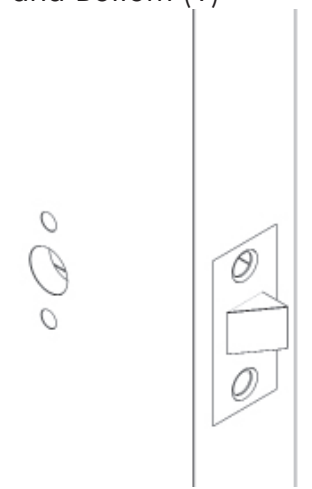

Step 3B:

Side by Side (2)
Holes for threaded rods.

*Drill all the way through to connect to the other side.

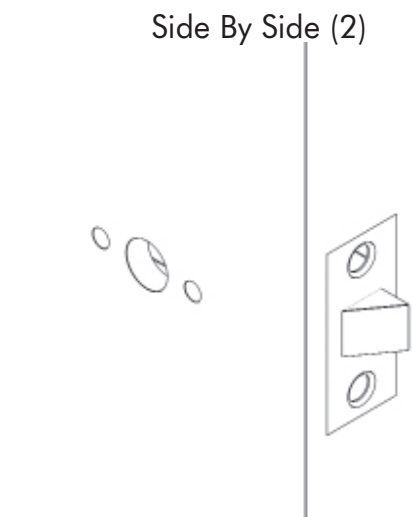

Step 4:

Line up the cylinder (part C) with the pre drilled holes and fix into place by screwing in the wood screws. Screws should go in the Top and Bottom like the picture on the left (1).

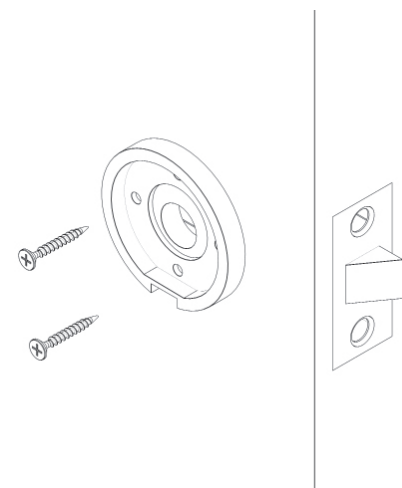

Step 5:

Feed through the threaded rods (part F) all the way to the other side. Reference Side by Side (2).

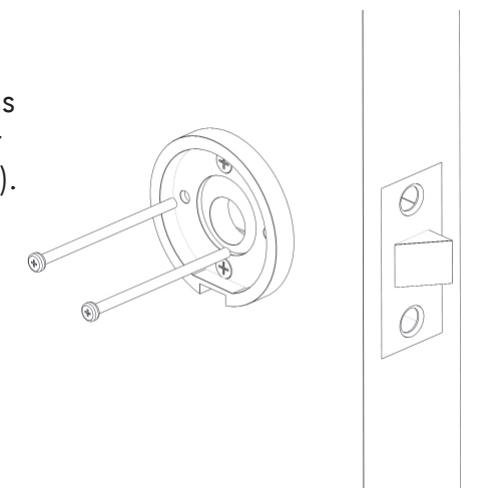

Step 6:

Connect the other cylinder on the other side of the door.
Repeat Step 4 and fix the wood screws in.

Screw on the end caps (part H) to the threaded rods coming out of the other end

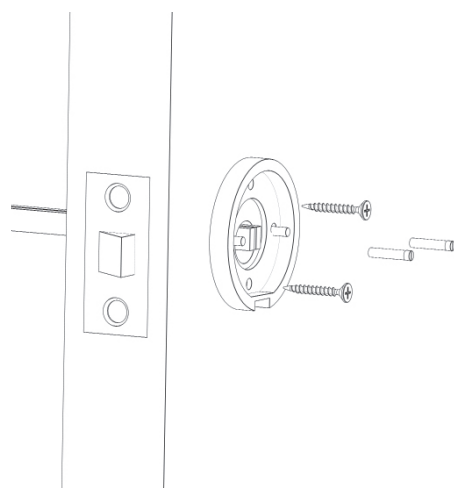

Step 7A:

Fix the mortice (part A) into the cylinder (part C).

Tighten to lock into place with the grub screws (part G) on the mortice using the allen key (part B).

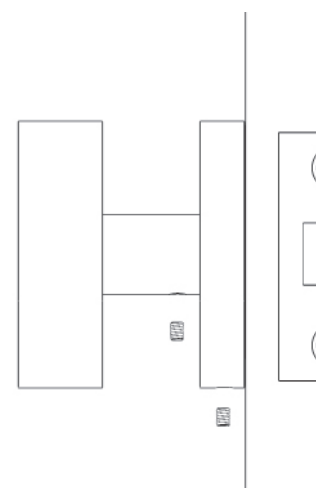

Step 7B:

Repeat Step 7A for the other side.

NOTE:

The grub screw on the base tightens the cylinder and the stem tightens to the spindle

